

MECHANICAL SPECIALTIES, LLC
975 85TH AVE SE
OLYMPIA, WA 98501

MODEL 6111 CARGO HOOK

INSTRUCTIONS FOR CONTINUED AIRWORTHINESS

OPERATING AND MAINTENACE MANUAL

MSI-MNL002

REVISION C

FAA ACTION		
Seattle Aircraft Certification Office		
<input checked="" type="checkbox"/> Approve	<input type="checkbox"/> EASA CS	<input type="checkbox"/> JARs
<input type="checkbox"/> Reject	<input checked="" type="checkbox"/> CARs	<input type="checkbox"/> CFRs
<input type="checkbox"/> Acknowledge	<input type="checkbox"/> Concur	<input checked="" type="checkbox"/> Accept
TSO/Project #s: STC SR00465SE, SR01738SE, SR01739SE		
Comments:		
ALS - Approved Remainder of ICA - Accepted		
Branch #	Concurrence	Date
AEG	Accepted	7/7/21
	via Memo	
		x3502
FAA Staff Specialist	Date	Phone
		x3502
SACO Manager	Date	Phone
Action Stamp #: 780-21-9942		
File Code: 8110.1.a.(2).SR00465SE		

REVISION HISTORY

Rev.	Author	Date	Description of Changes
B		6/18/09	Corrected items #51, 54 & #63 on parts list. (page 7)
C	N. Isaacson	07/07/2021	Reformatted Manual. Corrected Section numbering. Increased Overhaul Interval to three (3) years.

OPERATING AND MAINTENANCE INSTRUCTIONS

CARGO HOOK--MODEL 6111

1.0 GENERAL

The Model 6111 cargo hook provides a means to engage, lift and transport external loads. The hook assembly has an electrical release as well as a cable emergency release system, in order to allow releases to be conducted by the pilot in the cockpit. A manual release knob located on the side of the hook assembly allows cargo releases to be conducted by ground crew personnel.

The load beam is equipped with a return spring, to provide automatic relatching of the load beam after release of a load. A minimum load of 7 lb. must be applied to load beam to ensure opening either electrically or manually.

**BECOME FAMILIAR WITH YOUR FLIGHT MANUAL REGARDING EXTERNAL
LOAD OPERATIONS.**

2.0 AIRWORTHINESS LIMITATIONS

The Airworthiness Limitations section is FAA approved and specifies inspections and other maintenance required under §§43.16 and 91.403 of the Federal Aviation Regulation unless an alternative program has been FAA approved.

No airworthiness limitations.

Approved By: 
For Manager, Seattle ACO Branch

Date: July 12, 2021

3.0 OPERATION

3.1 LOADING

The load sling member or ring is guided into place on the load beam (9). The keeper (10) is spring loaded to close after loading to retain load.

3.2 GROUND CREW RELEASE

Manual release of the load beam may be accomplished by turning the manual release knob (21) in the counter-clockwise direction. The load beam return spring (28) returns the load beam to the latched position.

NOTE

ALWAYS ENSURE LOAD BEAM IS LATCHED
AND LOCKED PRIOR TO FLIGHT.

3.3 ELECTRICAL RELEASE

By use of a push button switch located in the cockpit, the pilot may release the load electrically.

3.4 MANUAL CABLE RELEASE

Emergency release is accomplished by a cable control system connected to the release arm (16) located inside the manual release housing (14, 15).

3.5 DAILY FUNCTION CHECK

A FUNCTIONAL CHECK OF ELECTRICAL AND MANUAL RELEASE SYSTEMS TO BE PERFORMED DAILY PRIOR TO COMMENCING LIFTING OPERATIONS.

4.0 ELECTRICAL SYSTEM

The two solenoid wires are connected to pins B and C of the MS3102E14S-6P connector (50), the circuit is closed at the push button switch located in the cockpit. Actuating the switch energizes the solenoid and allows the load beam to open.

5.0 INSTALLATION

5.1 CARGO HOOK INSTALLATION

The Model 6111 cargo hook replaces the redundant SP-7070-2 and SP-7102-1 cargo release assemblies, and attaches identically to the prior installation. Refer to Mechanical Specialties, LLC drawing HP6111-01 for installation of the 6111 cargo hook.

5.2 MANUAL RELEASE SYSTEM

The manual release system is identical to the installation referred to in Sikorsky S-61 maintenance manual. For mechanical release rigging instructions refer to Sikorsky S-61 maintenance manual.

6.0 MAINTENANCE INSTRUCTIONS

TIME BETWEEN OVERHAUL (TBO) OF CARGO HOOK IS 3,000 HRS OR 3 YEARS.

6.1 TOOLS AND EQUIPMENT

No special tools are required to disassemble or reassemble the cargo hook. However the following test equipment is required:

- A. 28 VDC 14 Amp power supply
- B. Pull test fixture
- C. Volt Ohmmeter

6.2 DISASSEMBLY

6.2.1 ACCESS TO THE CABLE RELEASE ARM (16)

To accomplish this remove the four screws (51) attaching the cover (14) to the housing (15). Remove cover, the release arm (16) will now be accessible for installation or removal of control cable, if the release arm is to be removed, the housing (15) must be removed. To accomplish this, remove the four screws (48) attaching the housing to the sideplate (6). The spring pin (36) can now be removed allowing removal of release arm.

6.2.2 ACCESS TO MAIN LATCHING MECHANISM

Remove manual release cover and housing (refer to Section 5.2.1). Remove safety wire from the four solenoid cover screws (40). Remove screws and cover (19). Remove electrical connector (50) (MS3102E14S-6P) from solenoid cover. Remove all remaining nuts and screws. Sideplate (6) may now be removed to expose internal latching mechanism.

If load beam (9) is to be removed, the return spring (28) must be removed. To accomplish this, remove the four bolts (38). Maintain a firm grip on spring housing as a slight load will be on spring. The spring housing may now be removed from trunnion (8).

NOTE

FURTHER DISASSEMBLY OF COMPONENTS IS NOT RECOMMENDED. IF FURTHER DISASSEMBLY IS REQUIRED, THE HOOK SHOULD BE RETURNED TO FACTORY FOR REPAIR.

7.0 SERVICE AND INSPECTION

- Clean all parts in cleaning solvent and dry with air.
- Inspect the cargo hook parts in accordance with Table 1.
- If bare aluminum exists, prevent corrosion by using anodize pen or Rustoleum Professional or equivalent spray paint as needed.

8.0 REASSEMBLY

Reassemble the hook in the reverse order of disassembly, noting the following procedures:

- Assemble all moving parts with MIL-G-81322D or equivalent grease.
- Ensure that the heads of screws (49) are flush or slightly below the surface of the sideplates (5, 6).

WARNING

**IMPROPER ASSEMBLY OF THE CARGO HOOK CAN
RESULT IN INJURY OR DEATH OF PERSONNEL.**

9.0 TESTING

9.1 ELECTRICAL CHECK

Place the leads of a volt-ohmmeter across the leads of the solenoid (30). Verify that electrical continuity exists. Attach one lead of a volt-ohmmeter to one of the solenoid leads, and the other ohm meter lead on sideplate (5 or 6) and ensure that continuity **does not** exist.

9.2 LOAD TESTING

Place hook in test cell. Perform the following load tests:

<u>LOAD</u>	<u>RELEASE METHOD</u>	<u>REMARKS</u>
7 lb.	22 VDC	Hold 5 seconds.
7 lb.	Manually	Hold 5 seconds.
5,000 lb.	22 VDC	Hold 5 seconds.
5,000 lb.	Manually	Hold 5 seconds.
11,000 lb.	22 VDC	Hold 5 seconds.
11,000 lb.	Manually	Hold 5 seconds.
22,000 lb.	DO NOT RELEASE	Hold 1 minute. Gradually reduce load to zero.

TABLE 1 – Component Inspection Methods

<u>ITEM</u>	<u>METHOD OF INSPECTION</u>	<u>REMARKS</u>
Bolts, Screws	Visual	Check for cross, deformed, or broken threads.
Springs (27, 28, 29)	Visual	Check for broken coils, deformed ends.
Bearings (44, 70, 71)	Visual	Check for freedom of rotation, binding, excessive wear.
Bushings (7, 12, 13)	Visual	Check for excessive wear. (See Note 1, 2)
Load Beam (9)	Visual	Check for wear, twisting, and bending. Check for burrs where load beam contacts roller (81). (See Note 3)
Latch & Roller (80, 81)	Visual	Check for excessive wear, and burrs where latch (80) contacts bearing (71), and where roller (81) contacts load beam (9), (See Note 3). Ensure the roller (81) rotates freely.
Lever (63)	Visual	Check for wear or bending.
Shaft & Arm Assy. (62)	Visual	Check for wear or bending.
Pins (31, 32, 34, 36, 60, 66, 67, 68, 69, 82)	Visual	Check for wear or bending.
Trunnion (8)	Visual	Check for wear or bending. (See Note 4)
Spring Housing (24)	Visual	Check for wear inside and out. If replacement is needed, replace spring (28) and retaining ring (23) as well.

Note 1 – Acceptable bushing (12) bore diameter tolerances: .751-.760

Note 2 – Acceptable bushing (13) bore diameter tolerances: .751-.760

Note 3 – If necessary, a very light smoothing with fine emery cloth or file is permissible.

Note 4 – Acceptable tolerance where trunnion (8) mates with bushing (7): .747-.742

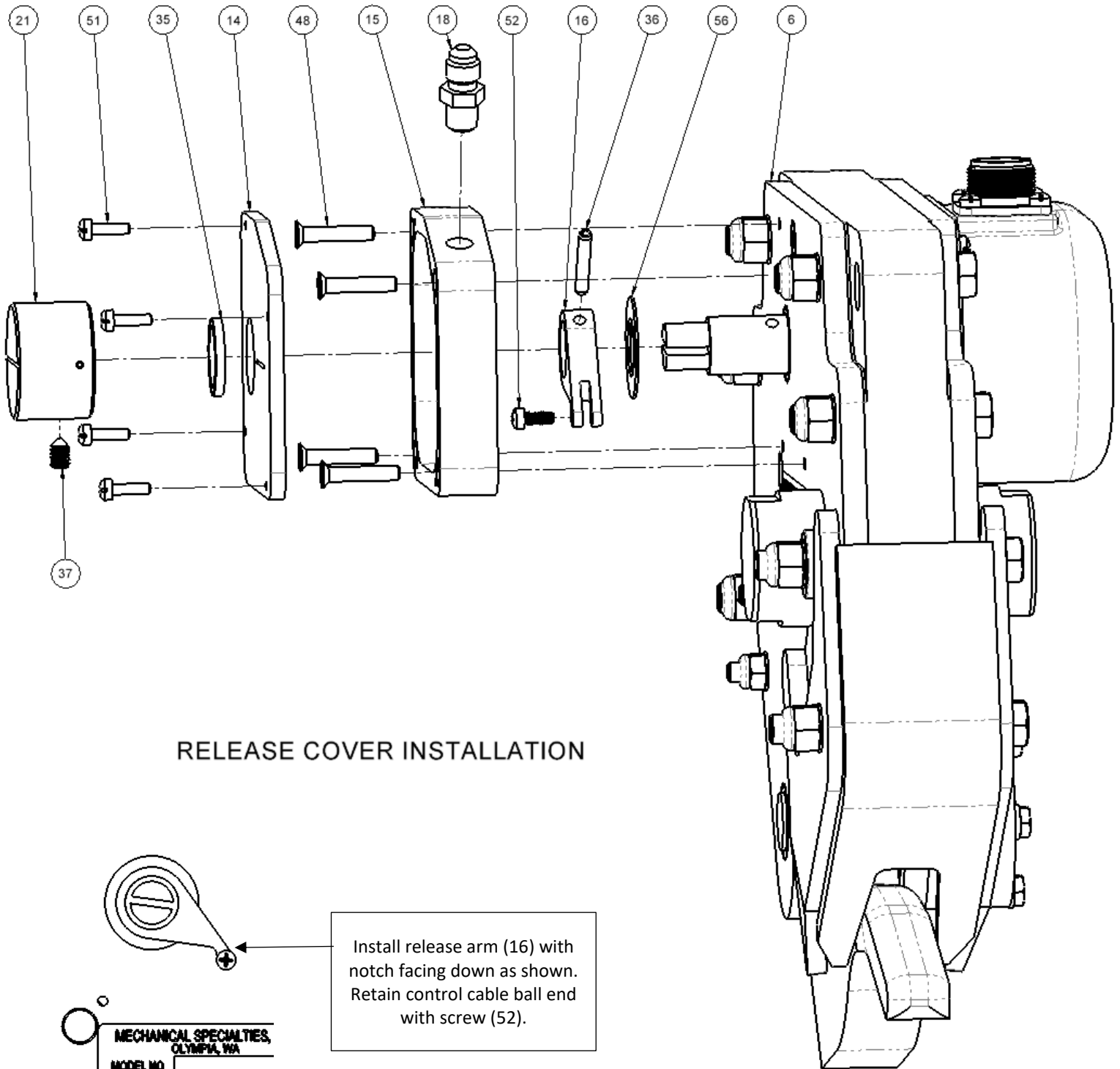

Install release arm (16) with notch facing down as shown. Retain control cable ball end with screw (52).

MECHANICAL SPECIALTIES,
OLYMPIA, WA

MODEL NO.	_____
SERIAL NO.	_____
CAPACITY	_____
FAA / PMA	_____



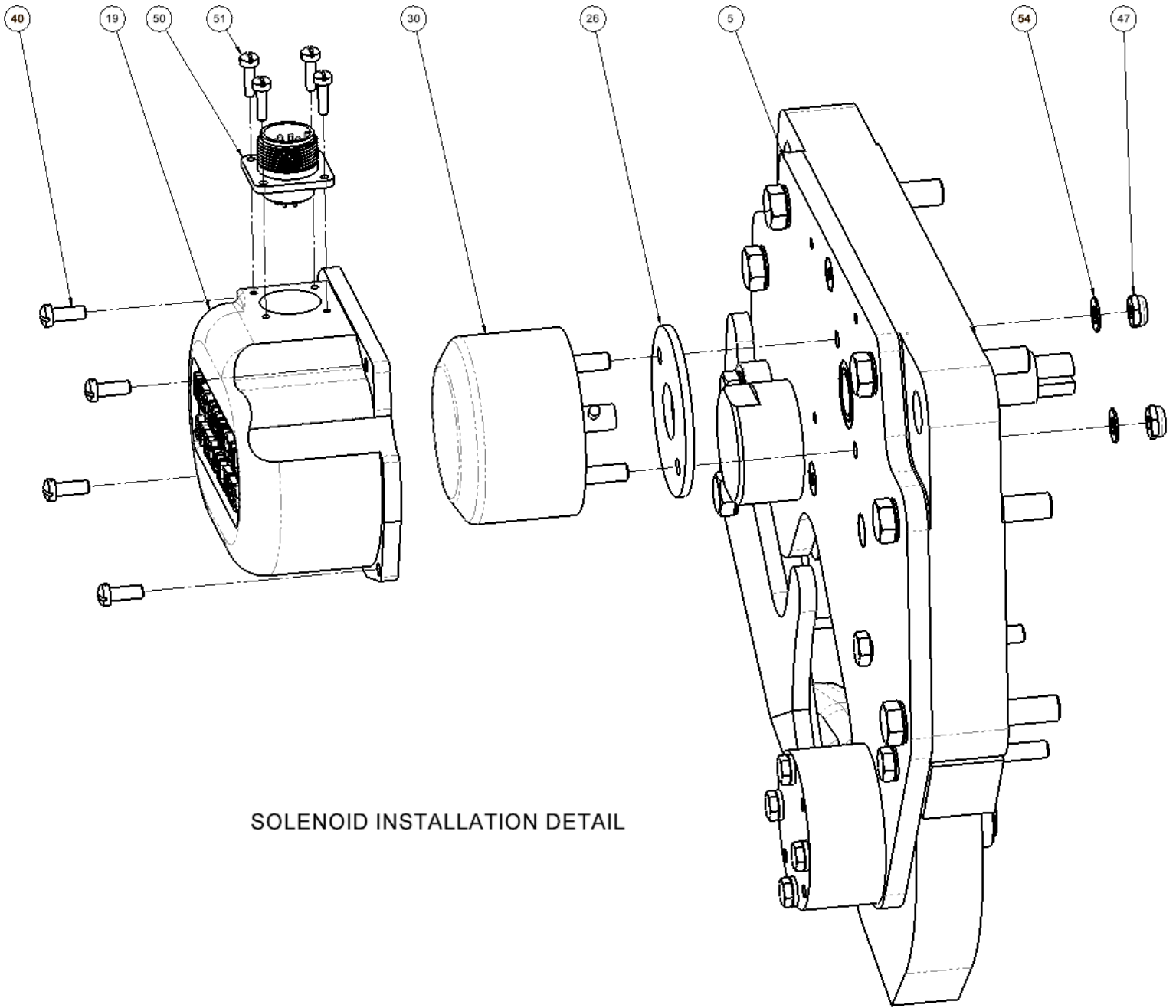

SOLENOID INSTALLATION DETAIL

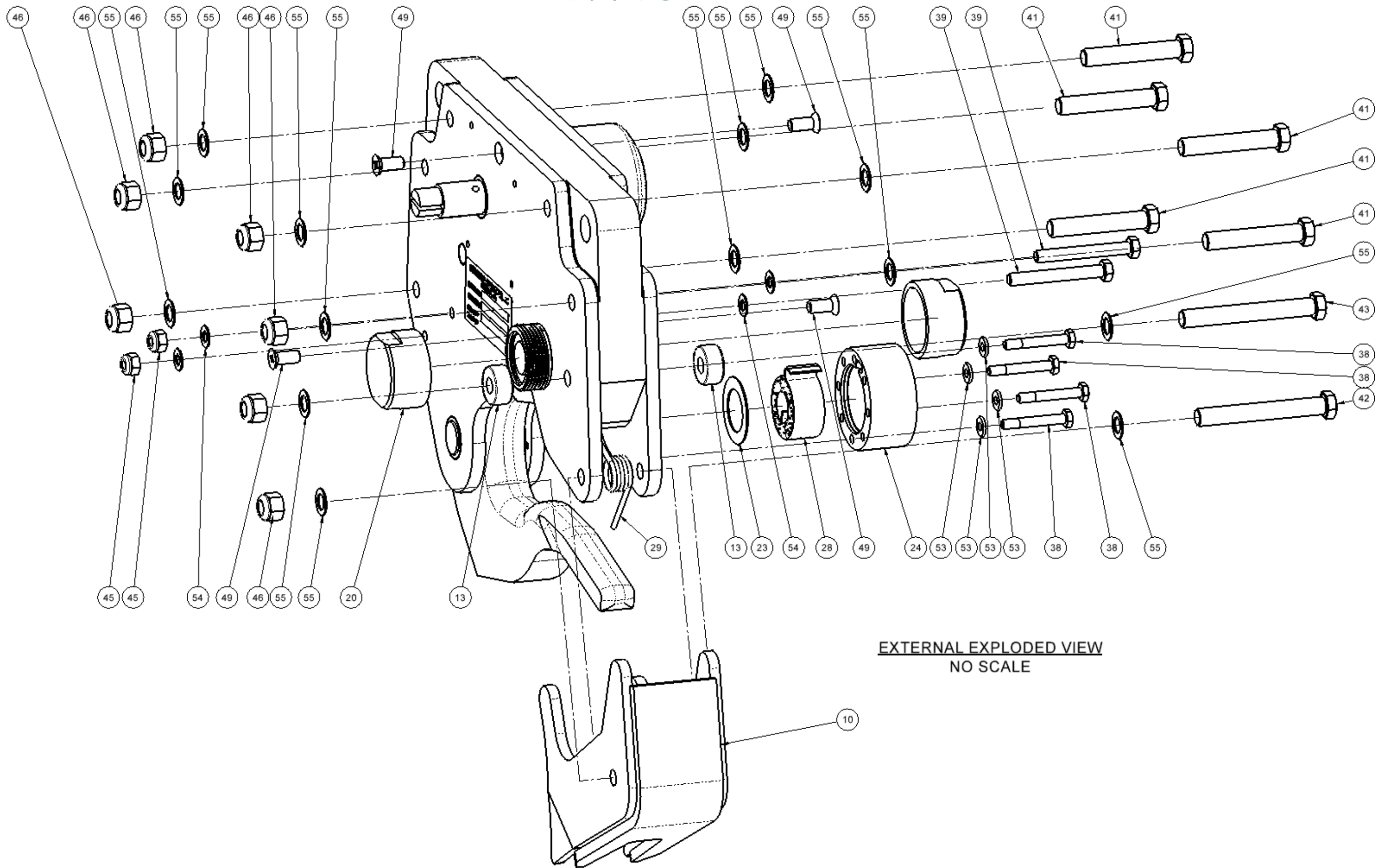

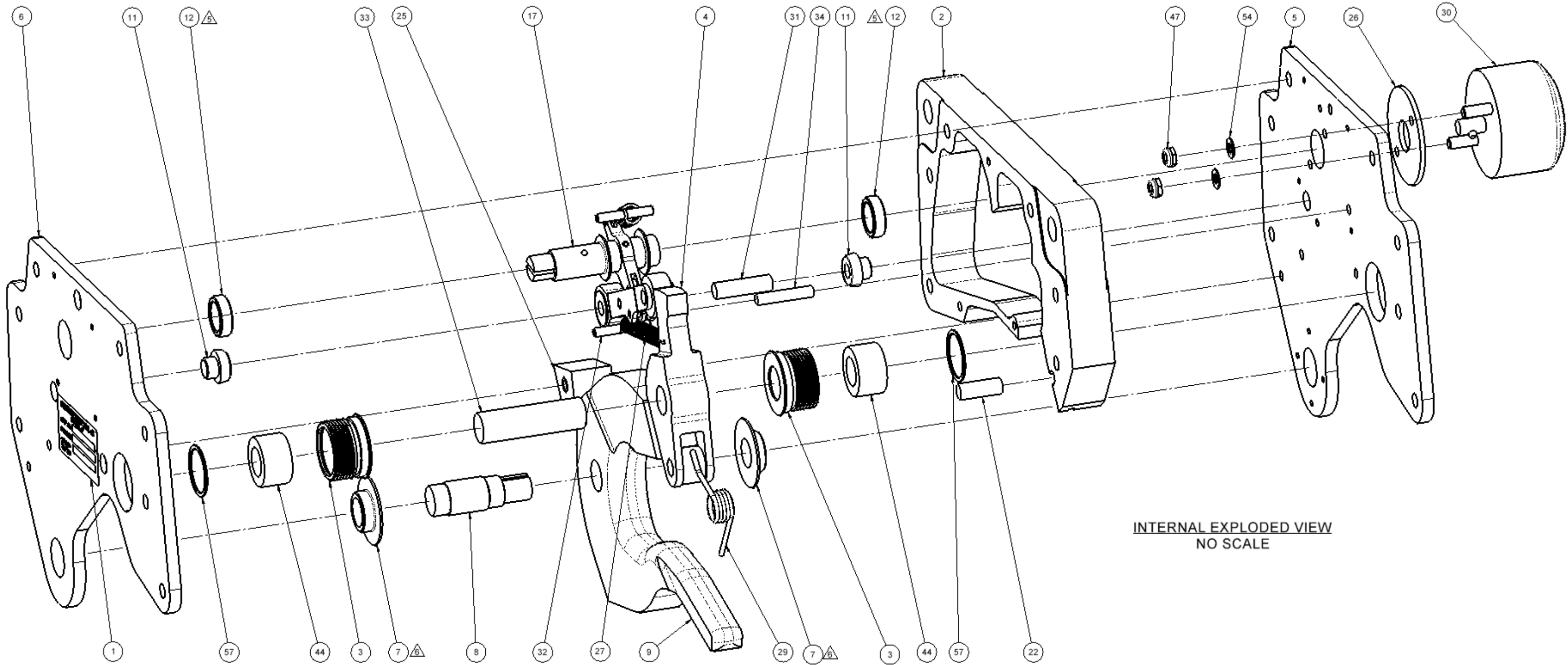

INTERNAL EXPLODED VIEW
NO SCALE

NOTE

SOME HOOKS MAY NOT HAVE WASHERS UNDER BOLT HEADS. THE Ø1/4 AND Ø3/8 INCH AN960 / NAS1149 .063 THICK WASHERS UNDER THE NUTS MAY BE REPLACED WITH TWO .032 THICK WASHERS AS SPECIFIED IN THE TABLE BELOW (#54 & #55), ONE EACH UNDER EACH NUT AND BOLT HEAD.

PARTS BREAKDOWN, CARGO HOOK ASSEMBLY

ITEM NO.	QTY	PART NUMBER	ALT. / LEGACY P/N	DESCRIPTION
1	1	1000-1	--	DATA TAG
2	1	611-010-002-001	1002-1	SPACER
3	2	611-010-017-005	1017-1	BEARING HOUSING
4	1	611-010-020-001	1022-1	LATCH ASSEMBLY
5	1	611-010-201-001	1001-1	SIDE PLATE, SOL. SIDE
6	1	611-010-202-001	1003-1	SIDE PLATE, NON SOL. SIDE
7	2	611-020-028-001	1028-1	LOAD BEAM BUSHING
8	1	611-020-029-001	1029-1	LOAD BEAM TRUNNION
9	1	611-020-030-001	1030-1	LOAD BEAM
10	1	611-020-049-005	1049-A1	KEEPER ASSY
11	2	611-040-010-001	1010-1	BOSS
12	2	611-040-012-001	1012-1	BUSHING
13	2	611-040-043-005	611-040-043-001 / 1043-1	BUSHING, KEEPER STOP
14	1	611-040-090-001	1090-1	COVER
15	1	611-040-091-001	1091-1	SPACER BLOCK
16	1	611-040-148-001	6148-1	LOWER RELEASE ARM
17	1	611-040-152-100	1152-A1	ASSY, SHAFT & ARM AND LEVER
18	1	611-040-154-001	3154-1	NIPPLE FITTING (MODIFIED)
19	1	611-050-010-001	1046-1	SOLENOID COVER, 6111
20	2	611-050-013-001	1013-1	BEARING CAP
21	1	611-050-016-001	1016-1	KNOB, MANUAL RELEASE
22	1	611-050-024-001	1024-1	BUMPER
23	1	611-050-033-005	1033-1	RETAINING RING
24	1	611-050-035-001	1035-1	SPRING HOUSING
25	1	611-050-058-100	1058-A1	BUMPER ASSEMBLY
26	1	611-050-080-001	6080-1	SOLENOID SPACER
27	1	611-060-025-005	6025-1	SPRING, LATCH
28	1	611-060-034-005	1034-1	SPRING
29	1	611-060-078-005	6078-1	SPRING
30	1	611-070-047-001	6047-1	SOLENOID ASSEMBLY
31	1	611-080-007-001	1007-1	PIN
32	1	611-080-011-001	1011-1	PIN, SPRING RETAINING
33	1	611-080-023-001	1023-1	LATCH TRUNNION
34	1	611-080-032-001	1032-1	PIN, LEVER STOP

PARTS BREAKDOWN, CARGO HOOK ASSEMBLY

ITEM NO.	QTY	PART NUMBER	ALT. / LEGACY P/N	DESCRIPTION
35	1	7411	--	SEAL
36	1	92373A217	--	SPRING PIN, \varnothing 5/32 X 1
37	1	92785A435	--	SET SCREW, 1/4-20 X 3/8
38	4	AN3-14A	--	BOLT
39	2	AN4-22A	--	BOLT
40	4	AN502-10-8	--	SCREW
41	5	AN6-22A	--	BOLT
42	1	AN6-30A	--	BOLT
43	1	AN6-31A	--	BOLT
44	2	MR12N	--	BEARING
45	2	MS21044N4	--	NUT, SELF LOCKING
46	7	MS21044N6	--	NUT, SELF LOCKING
47	2	MS21083N4	--	NUT
48	4	MS24693S276	--	SCREW
49	4	MS24694-S97	--	SCREW
50	1	MS3102E14S-6P	--	CONNECTOR
51	8	MS35265-30	--	SCREW
52	1	MS35265-43	--	SCREW
53	4	NAS1149F0363P	--	WASHER
54	6	NAS1149F0432P	--	WASHER
55	14	NAS1149F0632P	--	WASHER
56	1	NAS1149F1232P	--	WASHER
57	2	RR-125	--	RETAINING RING

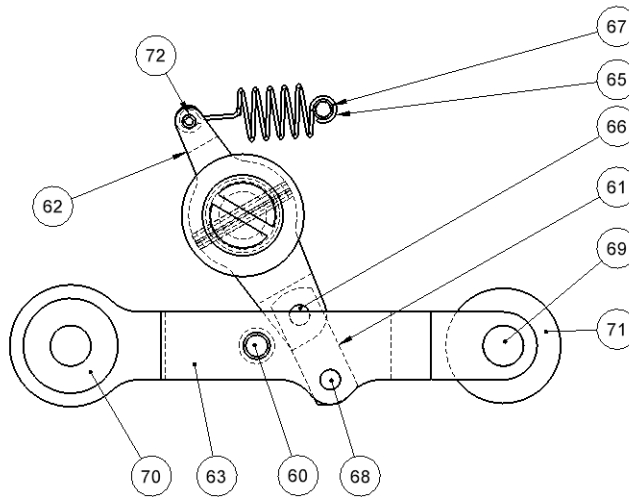

17. SHAFT, ARM, AND LEVER ASSEMBLY

PARTS BREAKDOWN, SHAFT, ARM, AND LEVER ASSEMBLY

ITEM NO.	QTY.	PART NUMBER	ALT. / LEGACY P/N	DESCRIPTION
60	1	202-103-4	3117-1	PIN
61	1	611-010-005-005	6005-1	LINK
62	1	611-040-004-005	1004-A1	SHAFT AND ARM ASSY
63	1	611-040-008-005	6008-1	LEVER
64	1	611-040-071-005	1071-1	BUSHING
65	1	611-060-031-001	3031-1	SPRING
66	1	611-080-006-001	6006-1	PIN, LINK
67	1	611-080-011-001	1011-1	PIN, SPRING RETAINING
68	1	611-080-026-001	6026-1	PIN
69	1	611-080-027-001	6027-1	PIN
70	1	6NBC914YZP	--	BEARING
71	1	6NBF817YJ	--	BEARING
72	1	92373A174	--	SPRING PIN, Ø 1/8 X 5/16

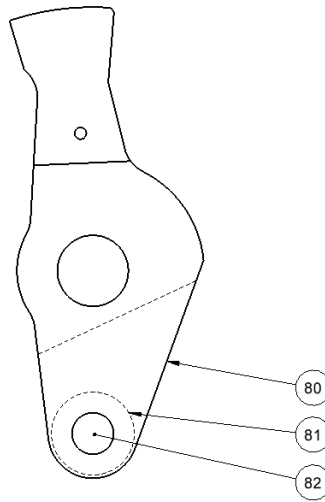

4. LATCH ASSEMBLY

PARTS BREAKDOWN, LATCH ASSEMBLY

ITEM NO.	QTY.	PART NUMBER	ALT. / LEGACY P/N	DESCRIPTION
80	1	611-010-022-005	1022-1	LATCH
81	1	611-010-023-001	1022-3	ROLLER
82	1	611-010-024-001	1002-2	PIN